

Close to our customers all around the world

**EUROPE****GERMANY**

molding.de@storopack.com
www.storopack.de

Metzingen

Untere Rietstraße 30
D-72555 Metzingen
Telephone +49 (0)7123 164-0
Fax +49 (0)7123 164-119

Krumbach

Fabrikstraße 1
D-74838 Limbach-Krumbach
Telephone +49 (0)6287 931-3
Fax +49 (0)6287 931-452

Langenau

Riedheimer Straße 32
D-89129 Langenau
Telephone +49 (0)7345 956-0
Fax +49 (0)7345 956-301

Mainleus

Spinnereistraße 15
D-95336 Mainleus
Telephone +49 (0)9229 991-3
Fax +49 (0)9229 991-505

Vechta

Auf der Lage 3
D-49377 Vechta
Telephone +49 (0)4447 80 08-0
Fax +49 (0)4447 80 08-545

FRANCE

molding.fr@storopack.com
www.storopack.fr

Saint Sébastien-sur-Loire

Rue de la Noé Cottée
BP 23637
F-44236 Saint Sébastien-sur-Loire
Telephone +33 (0)2 40 80 09 09
Fax +33 (0)2 40 80 09 00

Anetz

320, Rue d'Anjou
F-44150 Anetz
Telephone +33 (0)2 40 83 10 38
Fax +33 (0)2 40 83 32 31

Pont-l'Abbé

Rond-Point de Kernaria
CS 11004
F-29129 Pont-l'Abbé
Telephone +33 (0)2 98 66 06 06
Fax +33 (0)2 98 82 33 11

SWITZERLAND

molding.ch@storopack.com
www.storopack.ch

Stetten

Im Stetterfeld 1
CH-5608 Stetten
Telephone +41 (0)56 677 87 00
Fax +41 (0)56 677 87 01

SPAIN

molding.es@storopack.com
www.storopack.es

Mollet del Vallés

Polígono Industrial Can Prat s/n
E-08100 Mollet del Vallés
(Barcelona)
Telephone +34 93 570 61 50
Fax +34 93 570 15 36

Pamplona

Pol. Areta, C/ Badostain 22
E-31620 Huarte / Pamplona
(Navarra)
Telephone +34 94 8 335 059
Fax +34 94 8 331 461

CZECH REPUBLIC

molding.cz@storopack.com
www.storopack.cz

Telnice

Nádražní 191
CZ-664 59 Telnice
Telephone +420 544 254 052
Fax +420 544 254 977



5-litre System Solution



10-litre System Solution



21-litre System Solution



31-litre System Solution



36-litre System Box

Thermoshipping

Storopack develops and produces efficient thermal packaging which is designed for specific products and which takes account of the climate in which they are transported and stored. Temperature-sensitive goods at 2-8°C can thereby be despatched safely, quickly and economically.

System solutions for temperature-controlled transport for up to 24 hours at 2-8 °C

Pre-qualified, available from stock and attractively priced

Storopack offers five pre-qualified box sizes for temperature-controlled transport for up to a minimum of 24 hours at 2-8 °C. The system solutions are available from stock and as single items. To document the effectiveness of the boxes, all the solutions are pre-qualified in a winter and a summer scenario on the basis of the European norm AFNOR NF S99-700. The certification is issued for empty packaging without transported goods, the 'worst case scenario'.

All the system solutions consist of the following components:

- Polystyrene box
- Cooling agent (foam bricks)
- Outer / shipping carton
- Inner carton (payload)
- Packaging instructions
- Certification report

Benefits:

- Easy handling
- No additional layers between the cooling agent and the internal carton (payload box)
- Large proportion of the overall volume is usable
- The outer dimensions of the EPS boxes match the dimensions of a europallet: optimum use of packing space and warehouse resources



24-hour System Solutions – an overview

24 h system box	External dimensions in mm	Usable dimensions in mm	Usable volume in l	Empty weight incl. cooling agent
5-litre System Box	395 x 395 x 257	275 x 215 x 95	5	4,870 g
10-litre System Box	395 x 395 x 331	275 x 215 x 170	10	4,990 g
21-litre System Box	601 x 401 x 369	410 x 275 x 190	21	7,590 g
31-litre System Box	601 x 401 x 454	410 x 275 x 275	31	9,360 g
36-litre System Box	755 x 575 x 359	565 x 450 x 145	36	11,420 g



Prototype production

Prototype production with customised solutions

Individual solutions are produced in consultation with our customers. Our development team creates a draft design in the form of a CAD drawing. A prototype is then made which is used for further testing.



21-litre System Solution



Climate Chamber Test

Climate Chamber Test

We use our climate chamber to subject the solutions for our customers to very thorough testing. We can work with scenarios from -25 to +50°C. Regular calibration ensures that our readings are reliable.



10-litre System Solution

Prequalified with standardised summer and winter scenarios

Based on the European norm AFNOR NF S99-700

Diagram summer scenario / winter scenario

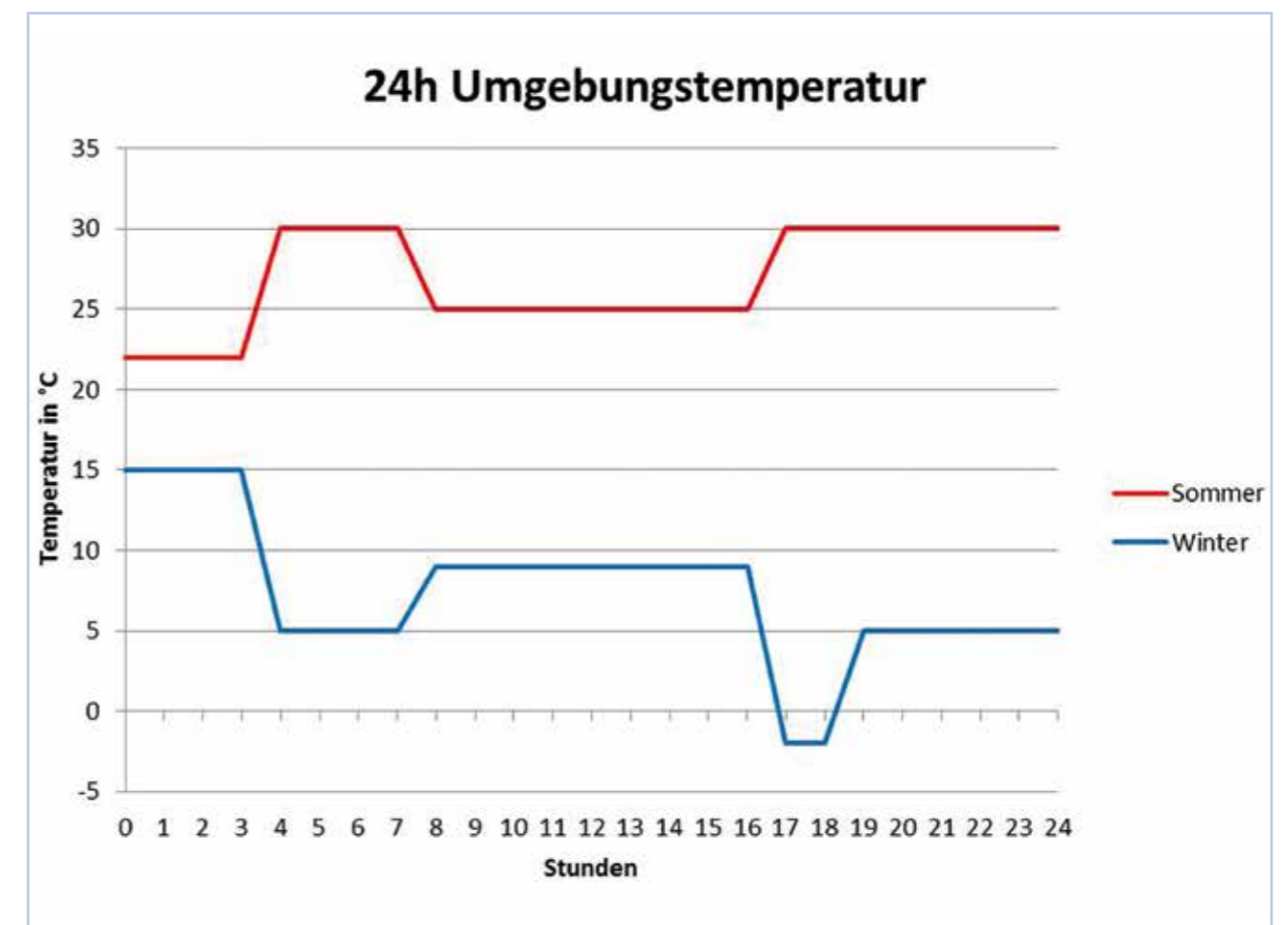

Explanation

We test using the above temperature scenarios. All the boxes are tested empty of products. The average temperatures are 27°C for the summer scenario and 7°C for the winter scenario.

System Box with 5 litres of usable volume

The version with 5 litres of usable volume is the smallest box in the 24-hour system solution range. Ideal for small quantities of temperature-sensitive products or special pharmaceuticals. The inner box shields the goods from direct contact with the cooling agent (foam bricks).

Product information

- External dimensions: 395 x 395 x 257 mm
- Dimensions of the inner box: 275 x 215 x 95 mm
- Usable volume: 5 litres
- Cooling agent: 3 foam bricks, each weighing 851 g
- Total weight of packaging including cooling agent and cartons: 2,552 g

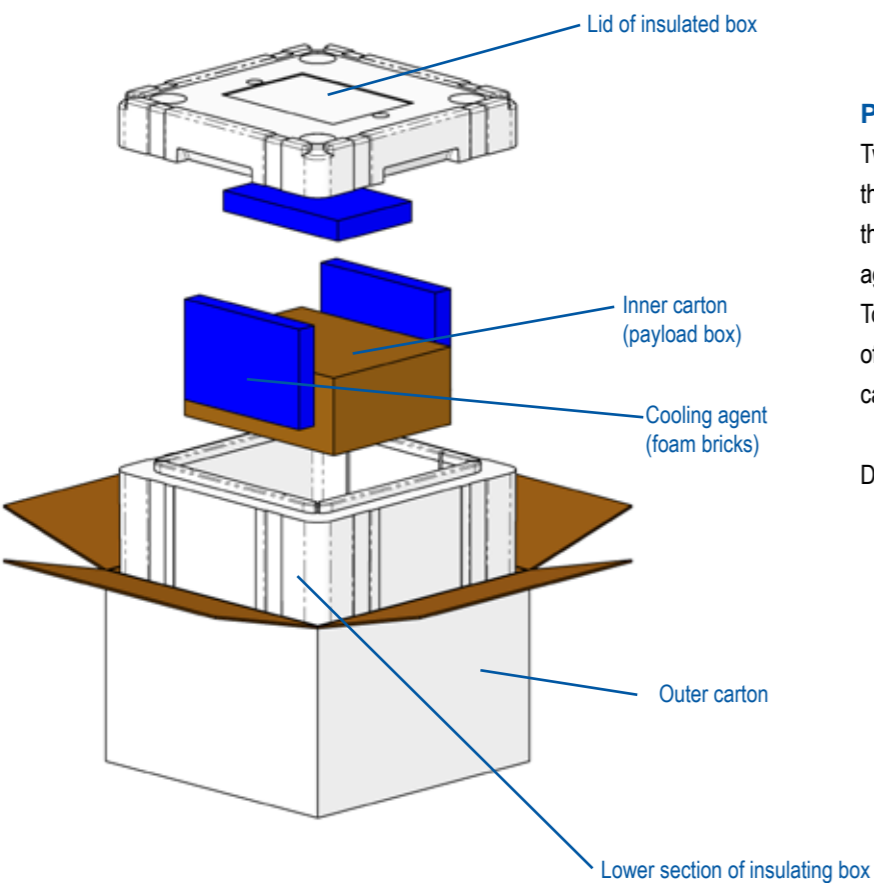

Packing information

Two foam bricks are placed along the long sides of the inner carton, the third is placed on the carton, the lid of the insulating box is closed and the package finished for consignment with adhesive tape. To make handling easier, the empty lower part of the insulating box can be placed in the outer carton at the start.

Detailed instructions on packing are provided.

Temperature simulation in the climate chamber

Parameters:

- Ambient temperature in line with AFNOR profile NF S99-700 with an average temperature of 27°C
- 2,552 g of cooling agent in the form of foam bricks
- Empty packing space (worst case scenario) for greater certainty

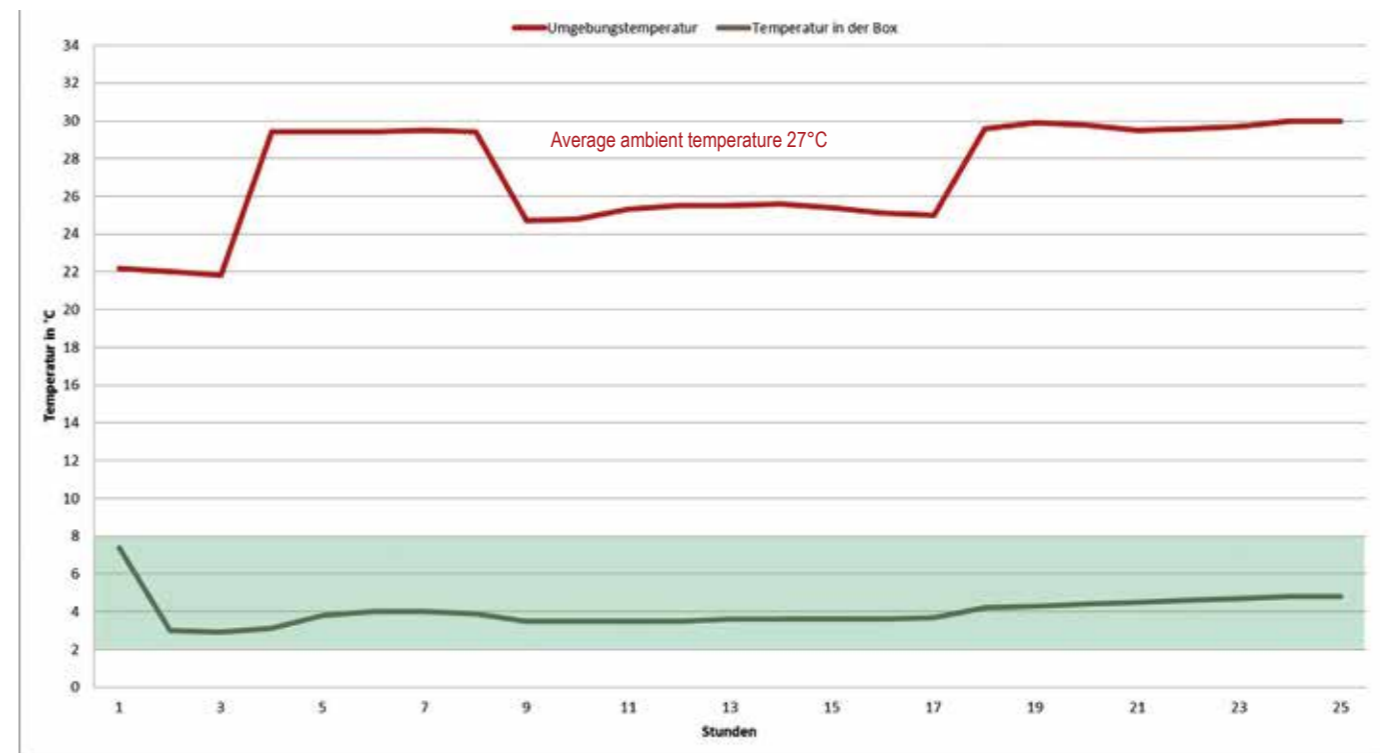

System Box with 10 litres of usable volume

The system box with 10 litres of usable volume is very versatile. With its rectangular shape, the insulated box can be used instead of a larger box for long or flat objects.

Placed around the inner carton, the three foam bricks ensure that the goods are kept at an even temperature.

Product information

- External dimensions: 395 x 395 x 331 mm
- Dimensions of the inner box: 275 x 215 x 170 mm
- Usable volume: 10 litres
- Cooling agent: 3 foam bricks, each weighing 851 g
- Total weight of packaging including cooling agent and cartons: 2,552 g

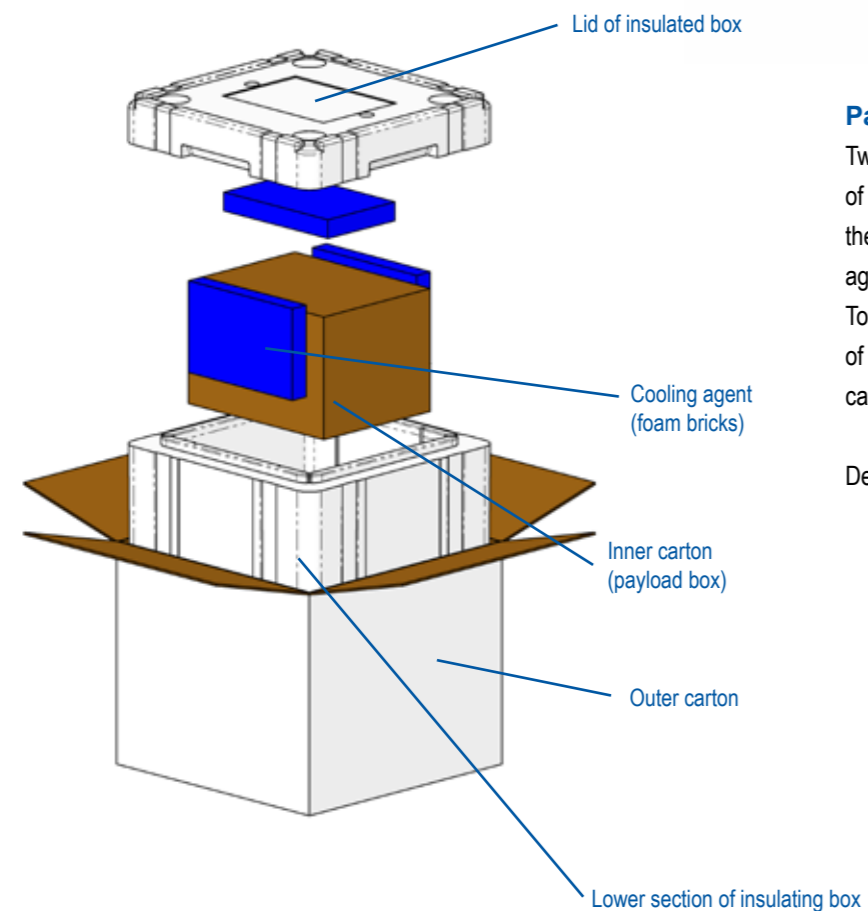

Packing information

Two foam bricks are placed along the longer sides of the inner box, the third is placed on the box, the lid of the insulating box is closed and the package finished for consignment with adhesive tape. To make handling easier, the empty lower part of the insulating box can be placed in the outer carton at the start.

Detailed instructions on packing are provided.

Temperature simulation in the climate chamber

Parameters:

- Ambient temperature in line with AFNOR profile NF S99-700 with an average temperature of 27°C
- 2,552 g of cooling agent in the form of foam bricks
- Empty packing space (worst case scenario) for greater certainty

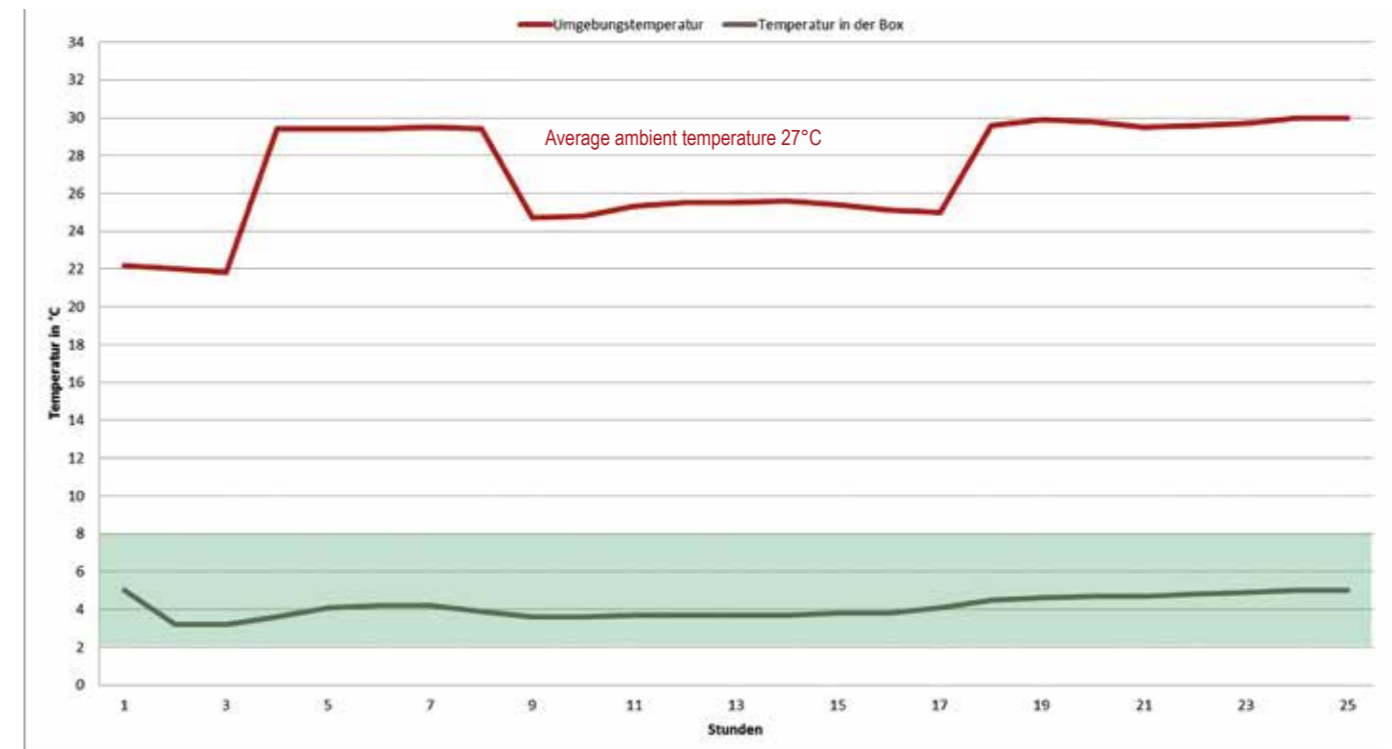

System Box with 21 l usable volume

This version is particularly long which makes it an all-rounder for the consignment of temperature-sensitive goods. With just three ice packs, the box is quickly made ready for use. It maintains a temperature of 2-8°C for more than 24 hours in a summer scenario at an average ambient temperature of 27°C.

Product information

- External dimensions: 601 x 401 x 369 mm
- Dimensions of the inner carton: 410 x 275 x 190 mm
- Usable volume: 21 litres
- Cooling agent: 3 foam bricks, each weighing 1,588 g
- Total weight of packaging including cooling agent and cartons: 4,763 g

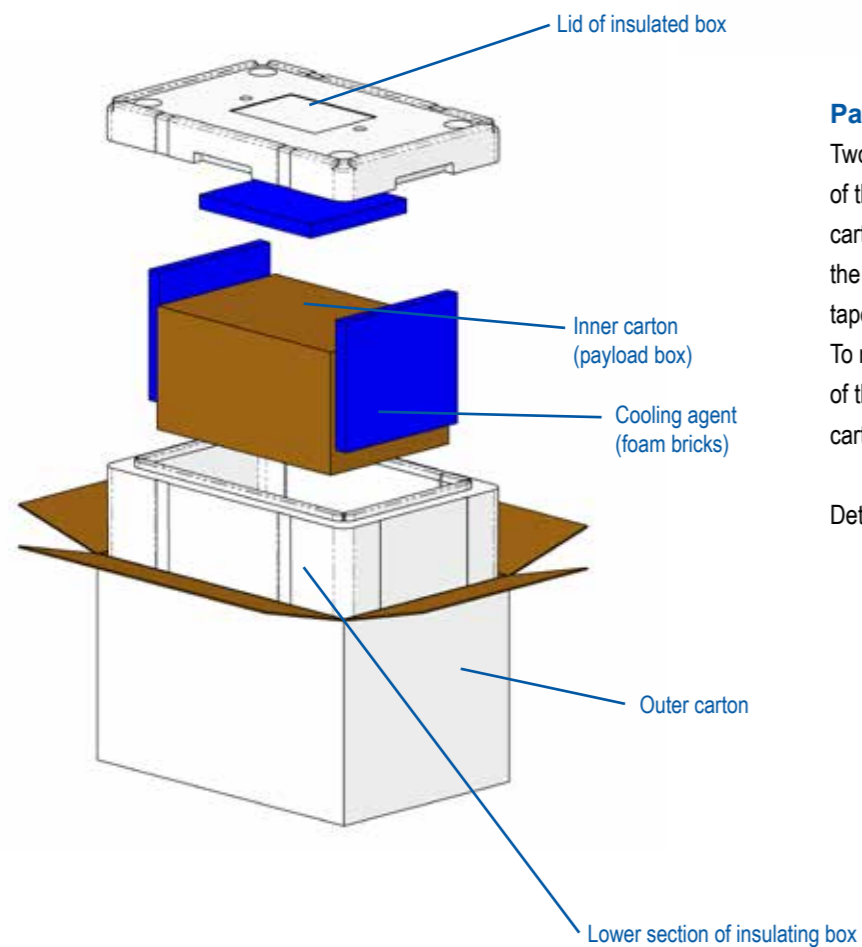

Packing information

Two foam bricks are placed along the narrow sides of the inner carton, the third is placed on top of the carton, the lid of the insulating box is closed and the package finished for consignment with adhesive tape.

To make handling easier, the empty lower part of the insulating box can be placed in the outer carton at the start.

Detailed instructions on packing are provided.

Temperature simulation in the climate chamber

Parameters:

- Ambient temperature in line with AFNOR profile NF S99-700 with an average temperature of 27°C
- 4,763 g of cooling agent in the form of foam bricks
- Empty packing space (worst case scenario) for greater certainty

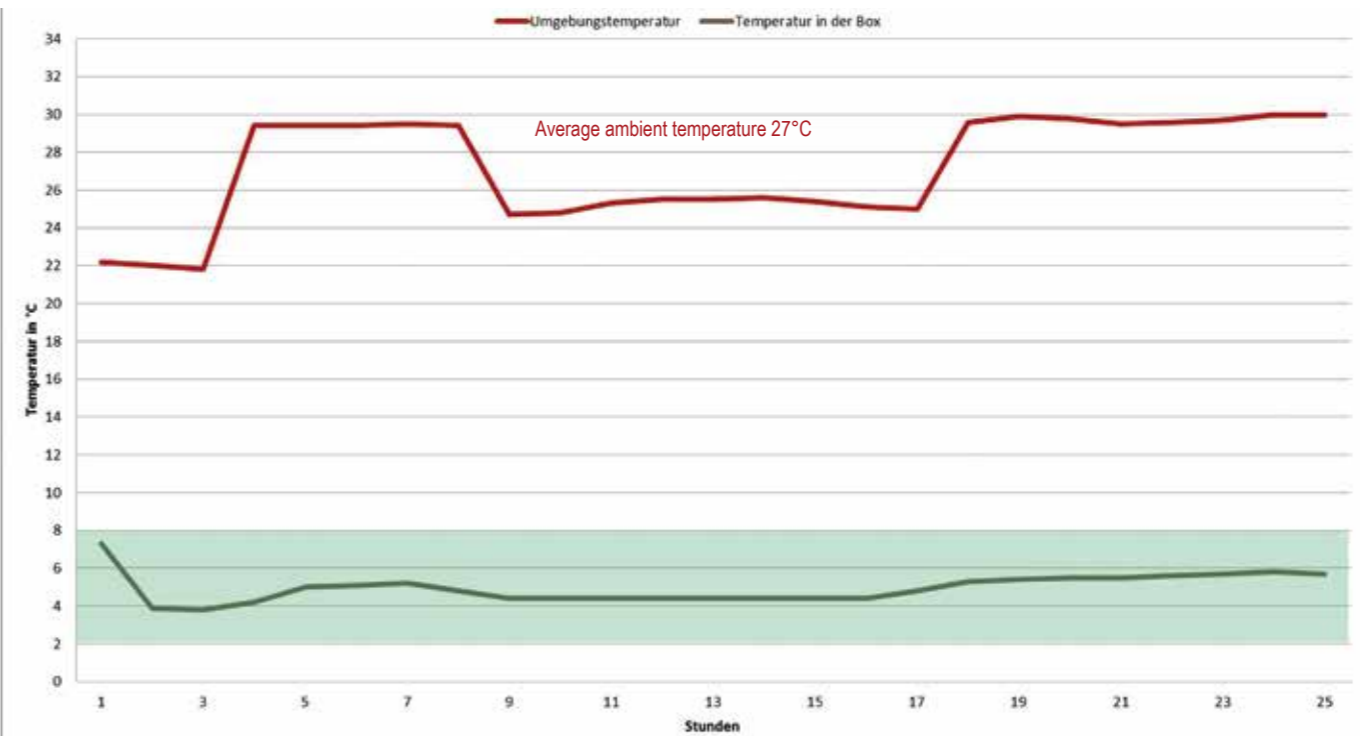

System Box with 31 litres of usable volume

The inside height of the version with 31 litres of usable volume is conveniently dimensioned at 275mm. This can accommodate products which need to be transported in an upright position. The box is quickly furnished with just four foam bricks making for rapid completion of the packing process.

Product information

- External dimensions: 601 x 401 x 454 mm
- Dimensions of the inner carton: 410 x 275 x 275 mm
- Usable volume: 31 litres
- Cooling agent: 4 foam bricks, each weighing 1,588 g
- Total weight of packaging including cooling agent and cartons: 6,350 g

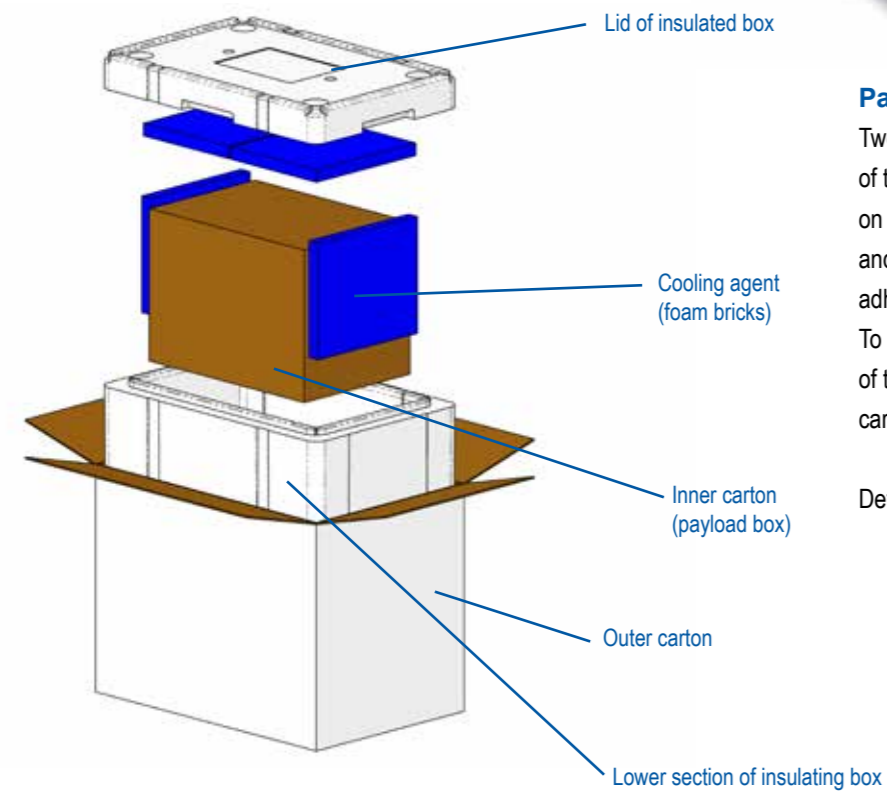

Packing information

Two foam bricks are placed along the narrow sides of the inner carton, the third and fourth are placed on the carton, the lid of the insulating box is closed and the package finished for consignment with adhesive tape.

To make handling easier, the empty lower part of the insulating box can be placed in the outer carton at the start.

Detailed instructions on packing are provided.

Temperature simulation in the climate chamber

Parameters:

- Ambient temperature in line with AFNOR profile NF S99-700 with an average temperature of 27°C
- 6,350 g of cooling agent in the form of foam bricks
- Empty packing space (worst case scenario) for greater certainty

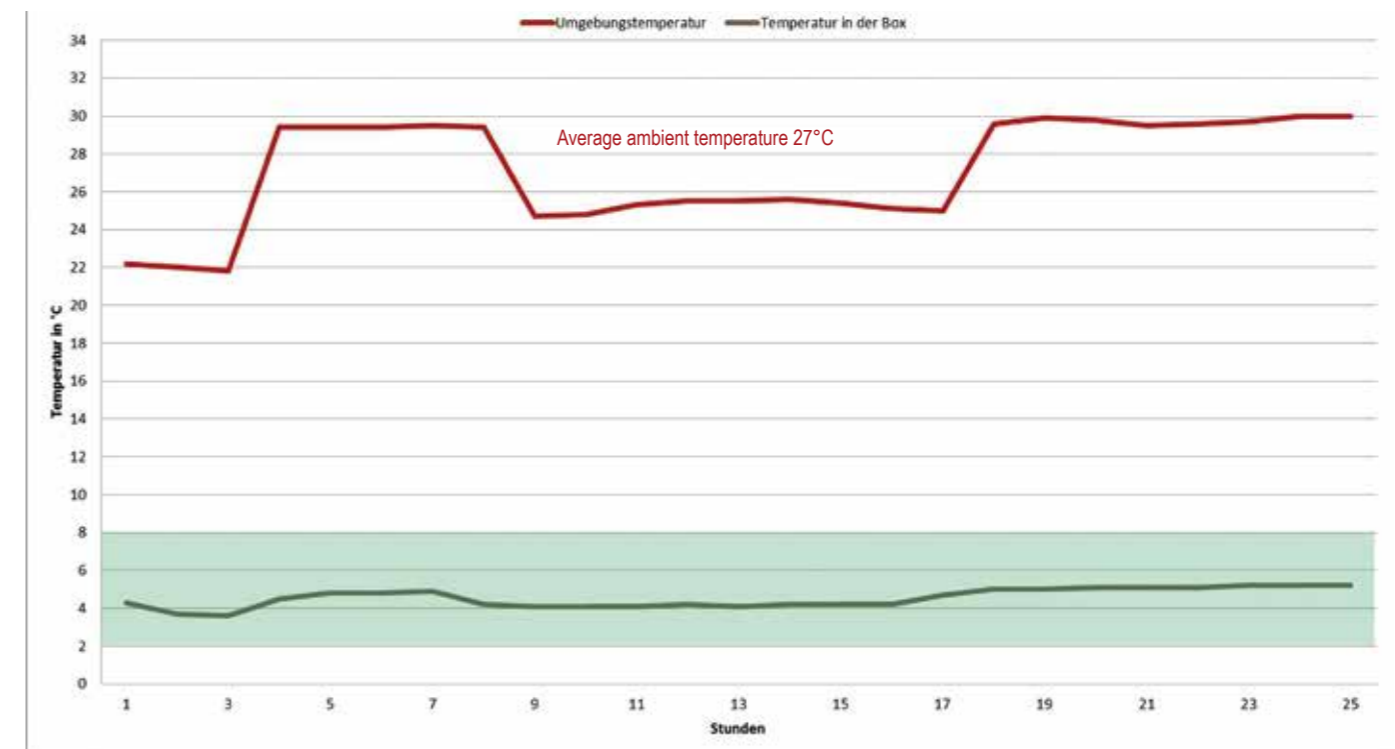

System Box with 36 litres of usable volume

The version with 36 litres of usable volume is the largest box in Storopack's 24-hour system solution range. 14 of these extra-large boxes can be stacked on a standard europallet measuring 800 x 1200 mm without wasting any space, providing a total volume of just under 504 litres per pallet. Other benefits: Easy handling and rapid packing with just five foam bricks per box.

Product information

- External dimensions: 755 x 575 x 359 mm
- Dimensions of the inner carton: 565 x 450 x 145 mm
- Usable volume: 36 litres
- Cooling agent: 5 foam bricks, each weighing 1,588 g
- Total weight of packaging including cooling agent and cartons: 7,938 g

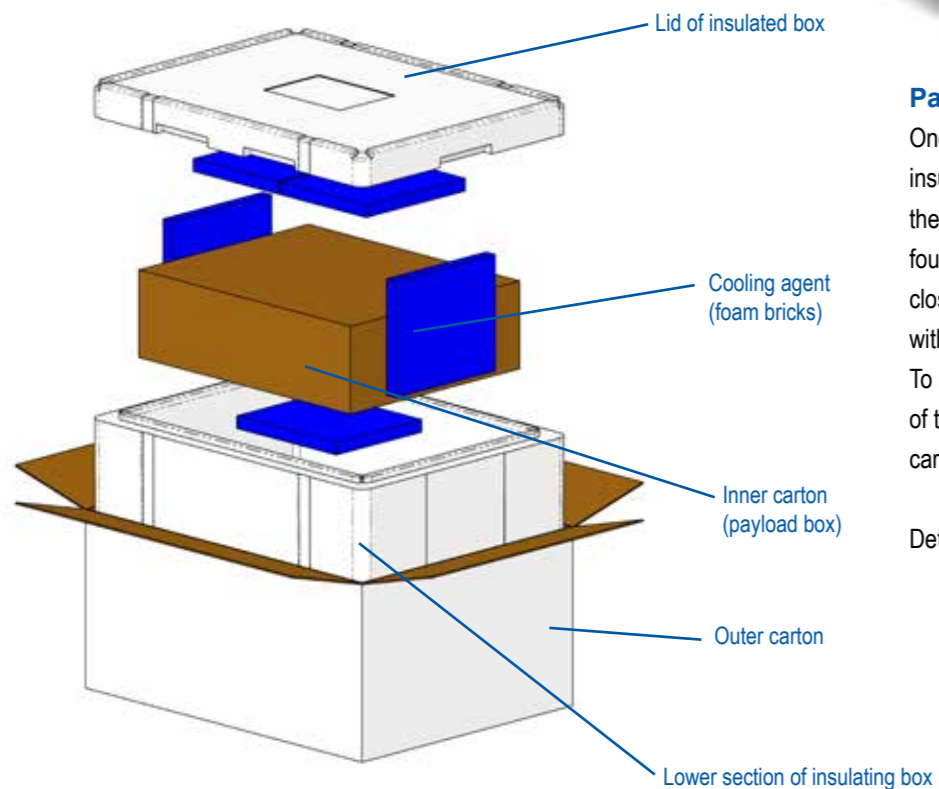

Packing information

One foam brick is placed on the floor of the insulating box. Two foam bricks are placed along the narrow sides of the inner carton, the third and fourth are placed on it, the lid of the insulating box is closed and the package finished for consignment with adhesive tape.

To make handling easier, the empty lower part of the insulating box can be placed in the outer carton at the start.

Detailed instructions on packing are provided.

Temperature simulation in the climate chamber

Parameters:

- Ambient temperature in line with AFNOR profile NF S99-700 with an average temperature of 27°C
- 7,938 g of cooling agent in the form of foam bricks
- Empty packing space (worst case scenario) for greater certainty

